



**IJITCE**

**ISSN 2347- 3657**

# International Journal of Information Technology & Computer Engineering

[www.ijitce.com](http://www.ijitce.com)



**Email : [ijitce.editor@gmail.com](mailto:ijitce.editor@gmail.com) or [editor@ijitce.com](mailto:editor@ijitce.com)**

## FOR HYPERTENSIVE PATIENTS, A REMOTE HRV (HEART RATE VARIABILITY) MONITORING SYSTEM BASED ON IOT (INTERNET OF THINGS) IS NEEDED.

Zainab Unnisa<sup>1</sup> · Dr.Syed Abdul Sattar<sup>2</sup>

Professor<sup>1</sup>, Lecturer professor<sup>2</sup>

Department Of ECE

NAWAB SHAH ALAM KHAN COLLEGE OF ENGINNERING & TECHNOLOGY  
NEW MALAKPET , HYDERABAD-500 024

### ABSTRACT

*HRV (heart rate variability) is a measure of the difference between consecutive heartbeats. Coronary disease complications, diabetes, autonomous dysrhythmic illness problems, including hypertension, and a wide variety of chronic degenerative medical diseases are all sensitive to HRV study. The doctor's use of a diagnostic, prognosis tool, and the effectiveness of the treatment provided are all enhanced when HRVs are exposed to specific medical issues. Borderline individuals, including those with and without a cardiac history, are often at risk for stroke and high-risk cardiac death. When medical treatment is needed, monitoring HRV values in these high-risk circumstances may be helpful. This article describes a low-cost, simple-to-use remote HRV monitoring device for borderline hypertensive patients that utilizes Internet of Things (IoT) technology. HRV characteristics are extracted using an IoT-based pulse sensor in the proposed system.*

## 1. INTRODUCTION

The execute design is the safest method of monitoring the patient's heart rhythm. The songs are influenced by the environment. To be able to live, the patients must be kept close together. In order of guy who it is, patient status inside the icu's add houses homes the mechanism has been discovered. Will you upload the information on the internet? What are the curing parameters going to be? This, too, can be operated remotely. the notion that anything is feasible (iot). The fundamental idea of the technique of propagation is that patients will be won by continuously tracking the proposed gadget via the internet. Heart rate and atmospheric conditions will be used to diagnose patient issues and provide support for different emotions.

### BLOCK DIAGRAM:

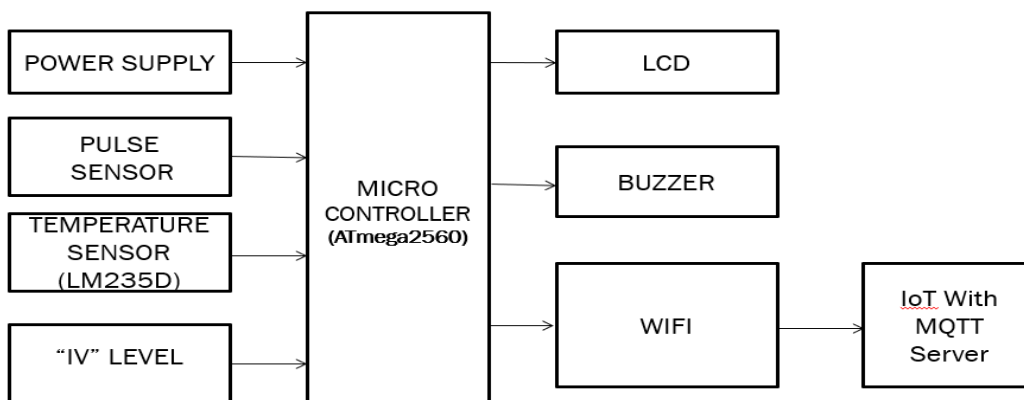

### **Description OfBlock Diagram:**

The block diagram for the project "AN IOT Dependent REMOTE HRV" is shown in the graphic above (Heart Rate Variability).

The following items are required for this project: 1. Microcontroller (Arduino Mega): a small built-in circuit in an embedded device that is customized for a certain process. A typical microcontroller has a single chip CPU, memory, and input/output peripherals.

2. Power Supply: A power supply is a collection of electrically powered devices that are usually found in powered components.

3. Pulse Sensor: A pulse sensor, also known as a heart rate sensor, is a device that monitors pulses and heart rate in real time.

4. Temperature sensor: A temperature sensor is a system that is designed to accurately detect the warmth or coolness of an item. The LM35 is a temperature-proportional IC temperature sensor with a temperature-proportional output (in degrees Celsius). The temperature can be calculated more accurately with the LM35 than with a thermistor.

5. IV Level: A gadget that measures the "IV" patent FLUID LEVEL in a container for a high and low fluid level track.

6. LCD (LIQUID CRYSTAL DISPLAY): LCD refers to the display technology utilized in laptops and other electronic devices. LCD displays, which include LED and gas plasma technologies, may be much thinner than cathode ray tube technology.

7. Buzzer: A piezo buzzer is a kind of electrical device that emits sound as a warning, alert, or notification.

8. WiFi Module (ESP8266): The ESP8266 WiFi module is a standalone SOC with a TCP/IP optimized protocol stack that will enable WiFi network connection to any microcontroller.

### **Arduino MEGA2560:**



The Arduino board is a microcontroller based on the Atmega 2560 that is open-source. The processing or cabling vocabulary is handled by the board's growing environment. With their simple to use platform, these boards have reloaded the automation sector, allowing even those with little technical expertise to learn the necessary programming skills and even run the Arduino unit. These boards are used to extend interactive artifacts independently; otherwise, we'll connect to programs on your PC such as Max MSP, Processing, and Flash.

## **1. SOFTWARE:**

Machine emulation is critical for completing the hardware deployment job effectively. What exactly does the term "machine simulation" imply? Now we'll go to the stage. Machine simulation technique includes a set of mathematical formulae for modeling a certain phenomenon.

It is, in essence, a software that allows the user to experience a simulation process without having to do it. If we agree on a professional level, you will use machine simulations to educate your customers how your software works. It may also be sociable, allowing customers to have a closer look at the features that interest them the most.

In our study, we mainly utilized Proteus version 8 as a simulation software. Below is a list of additional features that are required.

Algorithm from Algeria

1. The computer is turned on.
2. The LCD monitor's splash screen.
3. Sensor initialization and setup are steps three and four.
4. Data is recorded by the sensors.
5. C.P.U evaluates the data and performs the necessary tasks.
6. If the recorded values correspond to the typical situation, the LCD displays the message "NORMAL."
7. If the recorded values are abnormal, the LCD will display "ABNORMAL" and the gadget will sound a warning alarm buzzer.

## FLOW CHART:

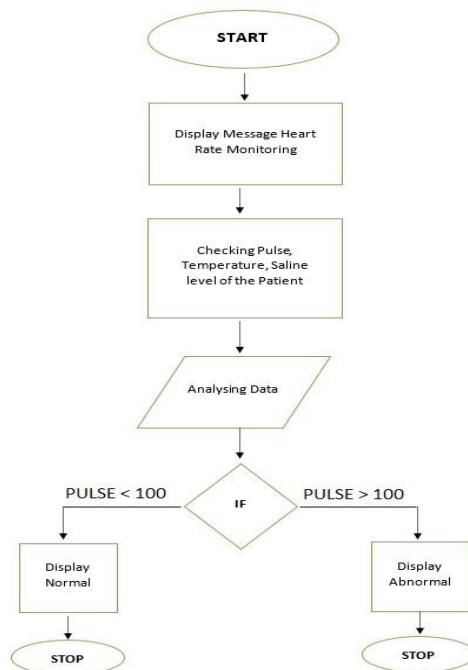

### 1. Result Analysis

Finally, we have achieved our target. As all the machinery is in our possession, we must implement the hardware. In brief, the whole process is as follows.





## 2. RESULTS

Finally, we applied the circuit successfully.

### Limitations of this project circuit:

The following are the disadvantages of this initiative:

- 1.Redundancy of data.
2. Increase the bandwidth requirements for overhead data and sensor networks.

We've previously seen the testing and spoken about how well the project circuit worked. Since then, the circuit limitations have been defined. Nonetheless, this circuit still has some room for improvement and modification in the future.

## 3. CONCLUSION

“AN IOT BASED REMOTE HRV (Heart rate variability) MONITORING SYSTEM FOR HYPERTENSIVE PATIENTS” is the title of the project. The system was successfully built and tested. The results show that the suggested device is suitable not only for real-time monitoring of a patient's heart rate and surrounding environment, but also for efficient remote control and emergency response.

## REFERENCES

1. J. H. Hong, J. M. Kim, E. J. Cha, T. S. Lee, "A wireless 3-channel ECG transmission system using PDA phone", *Convergence Information Technology Int. Conf.*, pp. 462-465, 2007.
2. M. Urooj, K. K. Pillai, M. Tandon, S. P. Venkateshan, N. Saha, "Reference ranges for time domain parameters of heart rate variability in indian population and validation in hypertensive subjects and smokers", *Int J Pharm Pharm Sci.*, vol. 3, pp. 36-39, 2011.
3. P. J. Tello, O. Manjarres, M. Quijano, A. U. Blanco, "Remote monitoring system of ECG and temperature signals using Bluetooth", *Information Technology in Medicine and Education (ITME) Int. Symp.*, vol. 2, pp. 860-863, 2012.
4. J. Mohammed, C. H. Lung, A. Ocneanu, A. Thakral, C. Jones, A. Adler, "Internet of Things: Remote patient monitoring using web services and cloud computing", *Internet of Things (iThings) 2014 IEEE Int. Conf. and Green Computing and Communications (GreenCom) IEEE and Cyber Physical and Social Computing (CPSCoM)*, pp. 256-263, 2014.
- 5.R.N. Kirtana, Y.V. Lokeswari (2017), "An IoT Based Remote HRV Monitoring System for Hypertensive Patients"Authors:

*6. Dr. Y Raja Sree Rao (PhD) Working as a Professor in Lords institute of Engineering and Technology, Hyderabad. She is having 31 years of Teaching Experience, Her area of interest is DE, Fault Tolerant Design, VLSI.*

*7. Syed Faizan Pursuing IV year Electronics and Communication Engineering in Lords institute of Engineering and Technology, Hyderabad.*

*8. Mohd Shoeb Pursuing IV year Electronic and Communication Engineering in Lords institute of Engineering and Technology, Hyderabad.*

*9. Mohd Junaïd Siddiqui Pursuing IV year Electronics and Communication Engineering in Lords institute of Engineering and Technology, Hyderabad*

*10. Mohamed Abid Mohamed Pursuing IV year Electronics and Communication Engineering in Lords institute of Engineering and Technology, Hyderabad*

