

# Monitoring agricultural environments via wireless sensor networks

Dr. DODLA PRATHYUSHA REDDI <sup>1</sup>, P VENKATESWARLU <sup>2</sup>

---

**Abstract :** *Wireless sensor networks have recently received a lot of interest in both the business world and our everyday lives because to the proliferation of sensor technology, MEMS, wireless communications, and the widespread use of wireless sensor. This study develops a wireless sensor network-based agricultural environment monitoring system, complete with hardware and software designs for sensor nodes, to achieve agricultural modernisation and agricultural environment protection. It has been shown via experimentation that the system can achieve remote real-time monitoring for unattended farm environment monitoring with a low power consumption, steady operating, and high accuracy.*

---

**Keywords:** *Wireless sensor networks, NRF2401, and environmental monitoring in agriculture.*

---

## Introduction

Every single point of monitoring the agricultural environment is far away, unique, and dispersed. Historically, gathering data at a scene has been a time-consuming and uncomfortable process for workers. Power and data are sent through cable in the conventional agricultural environmental monitoring system. Since installing lines is complex, significant investment costs are required, and man-made damage is common, obtaining real-time information on environmental monitoring is challenging. To address these issues, we developed a wireless sensor network-based system for monitoring environmental conditions in agriculture, including temperature and humidity. A wireless sensor network consists of several micro-sensor nodes, each of which is both compact and inexpensive. By use of wireless communication, it is

capable of arranging itself. Information gathering over the network relies heavily on data capture. When compared to conventional methods of keeping tabs on the environment, Three major benefits of wireless sensor networks make them a good choice for use in agricultural environment monitoring: (1) no wires need to be laid, the network needs to be deployed only once, and the human impact on the controlled environment is minimal; (2) the nodes are dense, resulting in accurate data acquisition; and (3) sensor nodes with a certain calculation, storage capacity, enabling collaboration among nodes is ideal for unattended remote monitoring. The future of environmental monitoring is moving in the direction of wireless sensor networks, which makes it possible to monitor environmental parameters in agricultural settings [1] [2].

---

Assistant professor<sup>1,2</sup>  
DEPARTMENT OF ELECTRONICS AND COMMUNICATION ENGINEERING  
P.B.R.VISVODAYA INSTITUTE OF TECHNOLOGY & SCIENCE  
S.P.S.R NELLORE DIST, A.P , INDIA , KAVALI-524201

---

## framework of the system

Figure 1 depicts the design of a monitoring system consisting primarily of four nodes: a sensor node, a

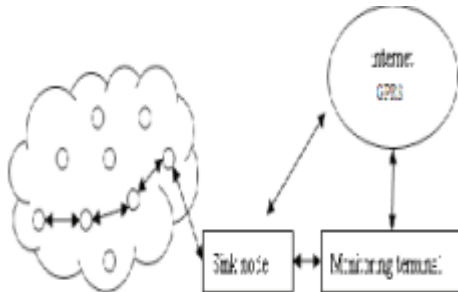

Structure of a wireless sensor network High accuracy and dependability in data collecting are guaranteed by a network of several, widely dispersed wireless sensor nodes in an agricultural setting. Data about environmental conditions is gathered by sensor nodes and sent to sink nodes through a network of intermediate nodes. More powerful than regular nodes, sink nodes gather and

sink node, transmission networks, and a monitoring terminal.

store data, perform computations, and integrate data; moreover, wireless sensor networks may establish connections with transmission networks and client terminals through sink nodes. Terminal clients receive the gathered data by cable or wirelessly (through GPS, GPRS, WIFI, or another radio communication method), and then evaluate the data to make a decision.

## sensor node hardware architecture Node of Sensing

wireless sensor networks rely on its nodes, or their individual sensors, to function reliably. The components of a sensor node include an antenna, a processor, a radio for sending and receiving data, and a power supply. Fig. 2 depicts the sensor's physical make-up. Other types of sensors may be used to detect and monitor environmental factors in various contexts. The data acquisition module performs sensing, data collection, and analog-to-digital conversion. The data acquired by the sensor nodes is controlled, stored, processed, implemented in a high-level network protocol, and the power work pattern is switched by the processor module. A

wireless This module's primary function is to exchange data with other nodes. We use a solar-powered battery system to keep the lights on. The components of a solar battery system are the solar energy panel, the solar charge controller, and the accumulator. The wireless sensor network requires little in the way of power, therefore normal operation may be guaranteed by using a combination of solar power and a battery. To achieve agricultural environment preservation or precision agriculture, the proposed system is primarily utilized for real-time monitoring of information like temperature, humidity, and so on.

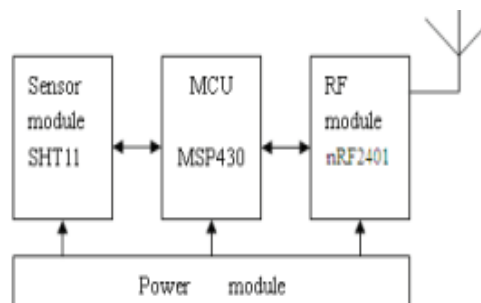

Fig.2. The hardware structure of sensor

## Data acquisition module

In this study, we use the measurement of humidity and temperature as an example of data collecting

since these two variables are among the most important to keep an eye on in an agricultural

setting. Selecting Sens iron's SHT11 temperature/humidity intelligent sensor allowed us to take advantage of its digital signal output, robust anti-interference capabilities, and high long-term stability all packed into a single chip. The SHT11 digital temperature and humidity sensor has an accuracy of 0.5°C over a temperature range of -40°C to +125°C; over a humidity range of 0% to 100% RH, with a measurement accuracy of 3.5% RH (20% RH 80% RH). Since the standard 14-bit (temperature) and 12-bit (humidity) measurement resolutions may be lowered to 12 and 8 bits, respectively [3], they find widespread usage in high-speed or ultra-low-power applications. Therefore, the SHT11 chip is an excellent choice for the system.

### Module for processing data

A tiny, low power, high speed, and high integration MCU is often required due to the central function of the microprocessor in the node of sensor networks. In this research, we use the MSP430F149, a 16-bit ultra-low power microcontroller that can switch between one active mode and four low power

**Table 1. NRF2401 work modes**

Mode	PWR_UP	CE	CS
Active(RX/TX)	1	1	0
Configuration	1	0	1
Stand by	1	0	0
Power down	0	X	X

The MISO port is used for receiving data and the MOSI port is used for sending data when the PWR\_UP, CE, CS, DR1, and CLK1 signals are active when the NRF2401 is connected to the MSP430F149 through the SPI serial programmable port, which is primarily used for extending peripherals and exchanging data. As can be seen in Figure 3, the nRF2401 communicates with the MSP430F149 microcontroller through an interface. In other words, after MSP430 has written the data that will be transferred to the data register of SPI, it

may go on to executing other programs without having to wait for the data transmission to complete. This system sets up the nRF2401 to operate in ShockBurst™ mode, one of the two active (RX/TX) modes it supports along with direct mode. The ShockBurst™ mode of operation of the nRF2401 enables a tremendous decrease in power consumption, a lowering of system costs, and a lessening of the likelihood of 'on-air' collisions, all of which contribute to greater communication efficacy and dependability.

### Module for wireless communication

Nordic Inc.'s 2.4 GHz ISM-capable nRF2401 chip is used in this design. Many of the functional modules necessary for steady operation are built right onto the chip, including the address decoder, FIFO stack regions, demodulation processors, clock processors, GFSK filters, low noise amplifiers, power synthesizers, and power amplifiers. The highest transceiver rate it can achieve is 1Mbps. The data may be sent 100 meters distant while using just 1.9V-3.6V of power, particularly in the power-down mode.

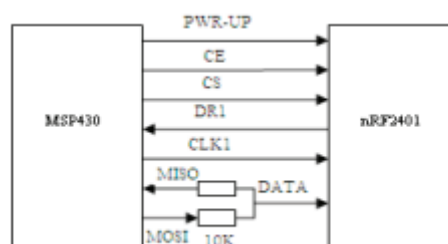

**Fig.3. The diagram of interface between nRF2401 and MSP430F149**

### Structure of Program Code

## Structured data frames

The ShockBurst™ transmission mode includes a preamble, an address, a payload, and a checksum, all of which are integral aspects of the communication

### Table 2. Data frame format

Preamble	ADDR	PAYLOAD	CRC
----------	------	---------	-----

A data header is a preamble. The data frames will be received only if their target address, ADDR, matches the address of the local hardware. The CRC function provides on-chip CRC creation and decoding in the nRF2401. PAYLOAD is the data part; the maximum length of the payload section for a ShockBurst™ RF package is 256 bits. Having more area for payload data in each package is

possible with shorter address and CRC, which may enhance transmission efficiency but reduce reliability. When a package is recognized as legitimate by the nRF2401 (i.e., the address and CRC match), the preamble, address, and CRC bits are discarded and the valid payload data is stored [5]. Figure 4 depicts the nRF2401 workflow.

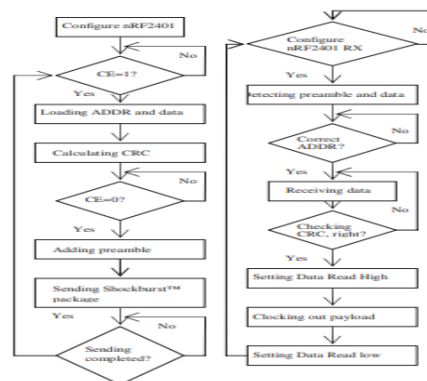
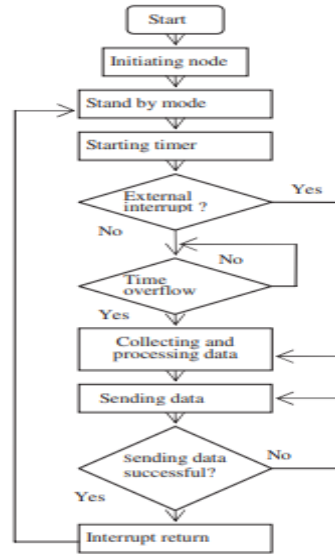

Fig.4. Workflow Chart ShockBurst™ mode of nRF2401

## The node's software architecture

The system software is written in C using the latest iteration of IAR Embedded Workbench, and it uses a modular program structure designed to facilitate resource sharing and reduce the burden of transplant procedures. Data collection and storage module, wireless communication module, alerting module,

wire communication module, etc. are all essential parts of the system software. The primary function of a sensor node is to detect agricultural environment characteristics in real time, collect data, and relay that data to a central monitoring station. Figure 5 shows a node-based workflow diagram.



Node-based process diagram (Figure.5) When the program begins, the sensor nodes will initialize, and then go into a low power consumption work mode while they wait to be awakened. The CPU will be in an idle state during this time, but the SPI port and interrupt system will continue to function normally. When it's time to collect data, the system will send out an acquisition request signal, and the nodes will get to work, gather the necessary information, and send it forth. Once data transmission is complete, the system will enter a low-power mode. If an interrupt request is received while the MCU is in power-saving mode, it will be forced to wake up and get to work in order to execute the interrupt service function. When the interruption completes, the system will go back into its normal low-power state. This cycle is one of several that the system uses to keep an eye on the agricultural environment [6]. 4.3.

Designing Monitoring Software C programming is used extensively in software development. LabVIEW is in charge of everything from data collection to analysis to storage. When the amount of data gathered reaches a certain threshold, the monitoring system will issue a warning and take the necessary steps to fix the problem.

### Test Outcome

Standard temperature is the measured, actual temperature as determined by thermocouple thermometers. The node's sensor will send the temperature readings to the control center. The temperature inaccuracy is less than 1 when compared to the actual temperature, which is within the tolerance of the design. You may see the test results in table 3.

**Table 3. Test result**

Node Nr.	Real Temperature(°C)	Measured Temperature(°C)	Error(°C)
1	-15.10	-15.80	0.70
2	-9.30	-9.00	0.30
3	0	0.30	0.30
4	14.30	14.10	0.20
5	22.50	22.80	0.30
6	38.65	39.15	0.50

### Conclusion

This study details the design of a wireless sensor network-based agricultural environment monitoring system that uses little power, operates reliably and precisely, and enables remote, real-time monitoring in the absence of human oversight. Monitoring. By

eliminating the limitations of conventional approaches, wireless sensor networks have the potential to revolutionize the way we keep tabs on the state of the agricultural environment. Changing the kind of sensors used for monitoring situations

like forest fires, precision agriculture, and so on is possible [7] because of the diversity of monitoring needs. Consequently, the wireless sensor network used for environmental monitoring plays a significant role that will ultimately boost future environmental protection efforts.

## References

[1]Li Bin, Tian Ya-ping. *Application of ZigBee Wireless Sensor Networks in the Industry Realm* [J]. *Journal of Shanxi university of science and technology* . Oct.2008.110-113.

[2]Mettam GR, Adams LB. *How to prepare an electronic version of your article*. In: Jones BS, Smith RZ, editors. *Introduction to the electronic age*, New York: E-Publishing Inc; 1999, p. 281–304

[3]Datasheet of MSP430F1x, <http://www.ti.com>

[4]Datasheet of SHT1x, <http://www.sensirion.com>

[5]Nordic VLSI ASA. “nRF240x ShockBurst™ technology”. <http://www.nordicsemi.com/>, 2003-02.

[6]Xingqiao Liu, Yijing Liu, Chengchun Li and Guohai Liu. “A New Multi-parameter Monitoring System Based on Wireless Sensor Network”. *2009 International Conference on Networks Security, Wireless Communications and Trusted Computing*, Vol. 2, pp. 755-758, April 2009.

[7]Ding Yonghong ,Sun Yunqiang. *Design of wireless data transfer system based on nRF2401* [J]. *Foreign Electronic Measurement Technology*. 2008, 27(4): 45-47(in Chinese).