



**IJITCE**

**ISSN 2347- 3657**

# International Journal of Information Technology & Computer Engineering

[www.ijitce.com](http://www.ijitce.com)



Email : [ijitce.editor@gmail.com](mailto:ijitce.editor@gmail.com) or [editor@ijitce.com](mailto:editor@ijitce.com)

# The MSP430 Microprocessor-Based Wireless Electronic Scale Design

S.Nagamani<sup>1</sup>, N.Srinivas Rao<sup>2</sup>, D.Kumar<sup>3</sup>, K.Sindhu<sup>4</sup>, K.Nagamani<sup>5</sup>,

## Abstract

Vegetable, fruit, and cookie shops should record all transaction details to better understand customer preferences and stock their shelves. The MSP430 microcontroller and the PTR2000 wireless connection module form the basis of the electronic scale's design. The scale is able to do more than just weigh people; it can also communicate with a host computer and follow commands. The strain bridge output signal circuit, time/data circuit, memory circuit, wireless module, and so on is all shown. Moving-average filtering is used to refine the data from the measurements. Visual Basic is used to create the user interface on the computer side.

## 1. Introduction

The applications for electronic weighing scales include the industrial, commercial, and consumer spheres. The typical scale, on the other hand, requires human entry of the commodity price and cannot save transaction details like date, time, item type, weight, etc. It's difficult to get your hands on and might be a pain to use. Good inventory management is difficult to obtain, and users cannot generate sales data or study client consumption patterns. Electronic scales in major supermarkets get around these problems, but they are too costly for regular shoppers and can't record sales data. The MSP430 microprocessor-powered wireless electronic scale is shown. It can receive commodity data from a PC via wireless communication, store sales data, and upload it to a PC, as well as obtain commodity prices via the commodity code.

## 2. System Architecture

The MSP430 microprocessor module, the sensor detection module, the real-time clock module, the data storage module, the wireless communication module, and the host computer make up the six components of the system. Figure 1 depicts the overall system architecture.

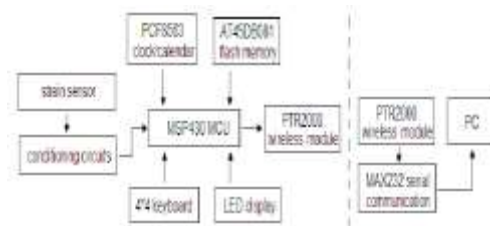

Figure 1: Organization of a System

Associate Professor<sup>1,2</sup>, Assistant Professor,<sup>3,4,5</sup>

Mail Id : [maniramesh2004@gmail.com](mailto:maniramesh2004@gmail.com), Mail Id : [srinivas.nune@gmail.com](mailto:srinivas.nune@gmail.com),

Mail id : [dh26kmr@gmail.com](mailto:dh26kmr@gmail.com), Mail Id : [karlapudisindhu516@gmail.com](mailto:karlapudisindhu516@gmail.com), Mail Id : [cse.nagamani@gmail.com](mailto:cse.nagamani@gmail.com),

Department of CSE,

Swarna Bharati Institute of Science and Technology (SBIT),  
Pakabanda Street, Khammam TS, India-507002.

MSP430F135 mixed signal microcontroller is the control core of system [1]. The output signal of strain sensor is initially conditioned by instrument amplifier and inverting amplifier. Secondly the conditioned signal uses the MSP430F135's built-in ADC module to convert analog signals to digital ones. The AD result and other memory-related data were processed by MSP430F135 and stored in flash memory (AT45DB081). The weighing result was displayed by LED which is drive by 74HC373 chip [2]. PTR2000, a wireless communication module, transmits the sales data. The PTR2000 is able to talk to the host computer via the usage of the MAX232 serial port communication chip. The VB programming language was used to create the receiving software.

### MSP430 Circuit

The MSP430F135 from Texas Instruments is a mixed signal microcontroller that has 48 input/output (I/O) pins, one universal serial synchronous/asynchronous communication interface (USART), and two 16-bit timers. The structure, when coupled with the five power-saving modes, is designed to improve the runtime of battery-dependent measuring tools. Maximum code efficiency is achieved via the device's potent 16-bit RISC CPU, 16-bit registers, and constant generators. The DCO enables for a rapid transition from sleep to active operation, often taking less than 6 s. MSP430F135 requires a stable 5V and 3.3V double power source based on the TPS70302 chip, and a reliable reset sequence.

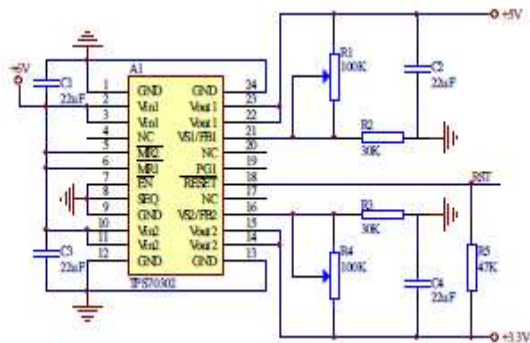

**Figure 2: A TPS70302-based power supply and reset sequence circuit.**

Adjustable resistances R1 and R4 in Fig. 2 allow for regulation of the 5V, 1A, and 3.3V, 2A outputs of the TPS70302 chip, whose input voltage is 6V. When SEQ=0, 5V is generated from the TPS70302 chip's RESET pin. By 3.3V, hence an effective reset sequence for MSP430 is provided.

### Strain Sensor Signal Acquisition Circuit

The system uses a strain sensor of type YZC-1B, with a maximum load of about 5 kg. The utilized full bridge sensor has a full-scale output voltage of 2.00.002mV/V at its rated load of about 5 kg. The target is a resolution of 1g for the sensor signal. Totalling 10,000, and displaying the result on an LED. The maximum output voltage of the bridge sensor is 10 mV, or 5 V multiplied by 2 mV/V. Due to the low output voltage of strain sensors, amplification by a factor of a thousand is required prior to AD conversion. A single-order low-pass filter and an instrument amplifier make up the conditioning circuit. The INA326 are rail-to-rail input and output precision instrumentation amplifiers [3] that provide good performance at a cheap cost. The input common-mode ranges of these instrumentation amplifiers go beyond the positive and negative rails, and they have extremely low DC errors. Because of these characteristics, it may be used in precision-oriented tasks. To determine the profit, we need (1).

$$G_{\text{gain}} = \frac{R_2}{R_1} = 1000 \quad (1)$$

The gain equation allows one to explicitly estimate the degree by which stability and temperature drift of the external resistors setting the gain will impact gain. (1). the resistances R1 and R2 must have minimal temperature drift. The OPA2234 is the one-order low-pass filter's building block. OPA2234 is compatible with supplies ranging from 2.7 V to 36 V. success in a remarkable [3] way. The electricity for this is provided by the same source as that for the Strain Bridge and the INA326. R11 and C7 in Fig. 3 determine the filter's cutoff frequency. Power interference was completely wiped out, and the strain bridge output signal morphed very slowly. The low-pass filter's gain may be adjusted with the help of variable resistance R12. The conditioned voltage range of 0–3.3V is compatible with the ADC module in the MSP430F135. Both the internal 1.2 V reference and an externally attached reference voltage are supported by the MSP430 12-bit sigma-delta ADC. In this case, the reference voltage is supplied via an external resistor divider. This has the benefit of establishing a Vcc independent, ratio metric measuring method due to the fact that the bridge sensor is powered by the same voltage source. Using the ADC module's internal voltage reference to power the bridge sensor would result in measurements that fluctuate with changes to Vcc.

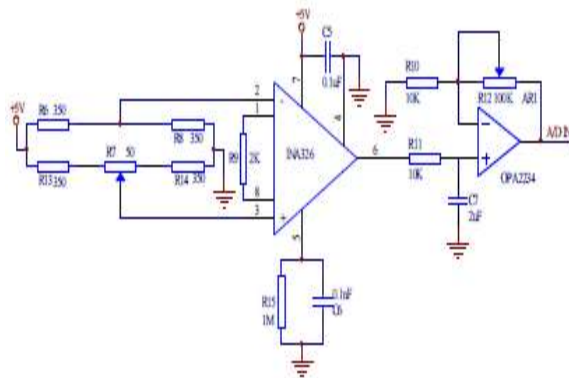

Fig.3 Strain sensor signal acquisition circuit

### PCF8563 Real-time Clock/Calendar

The real-time clock/calendar chip PCF8563 provides the weighing system's time and data information. Power consumption has been minimized in the PCF8563, a CMOS real-time clock/calendar. In addition to the programmable clock and interrupt outputs, there is also a voltage-low detector. All data and addresses are sent in a serial fashion through a two-wire, two-way I2C-bus. 400 kbit/s is the maximum speed of the bus. After each byte of data is read or written, the internal word address register is incremented by one. Although not all bits are implemented, all 16 registers are intended to function as addressable 8-bit parallel registers. Control and status information are stored in the first two registers (memory addresses 00h and 01h). The PCF8563 application circuit is shown in Figure 4. Figure 4 shows that PCF8563 has two power sources. The 3.3V output of the TPS70302 is one often used power source. A 3V battery is an alternative that continues to function even when the power is off. Since the system is powered by a 3V battery, saved data and time will be preserved even if the battery dies.

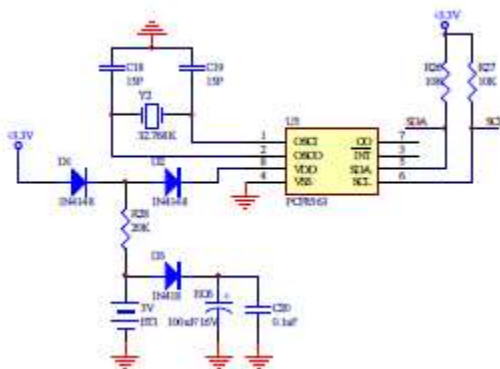

Fig.4 PCF8563 application circuit

### AT45DB081 Flash Memory

AT45DB081 flash memory stores the specifics of each transaction, including the time stamp, item description, and quantity purchased. Users may get insights into customer behavior and improve inventory management using this. The AT45DB081 is a serial interface Flash memory that operates at just 2.7 volts, making it ideal for use in-system. Reprogramming. Data in the Data Flash is accessible sequentially through a serial interface, as opposed to ordinary Flash memory's random access via multiple address lines and a parallel interface. The reduced switching noise, smaller package size, and fewer active pins are only a few of the benefits of the serial interface's simplicity in hardware design. The device's high density, low pin count, low voltage, and low power make it ideal for usage in a wide variety of commercial and industrial settings. The Data Flash is often used for storing digital audio files, pictures, and other information. The gadget can function at clock frequencies of up to 10 MHz and uses an average of 4 mA during active read. The application circuit for the AT45DB081 is shown in Figure 5.

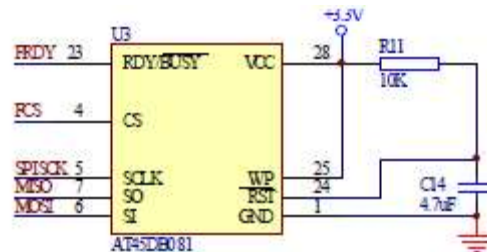

Fig.5 AT45DB081 application circuit

### Wireless Communication Module

Wireless communication is handled using a PTR2000-based module. It employs a pair of PTR2000 modules. One is linked to the level-conversion chip MSP430F135, while the other is linked to the MAX232 (see Fig. 6). Here, we use the middle value (5.0 V) of the recommended range (2.7 V) for the PTR2000 module. For optimal data transmission, 9.6kbit/s~19.2kbit/s.

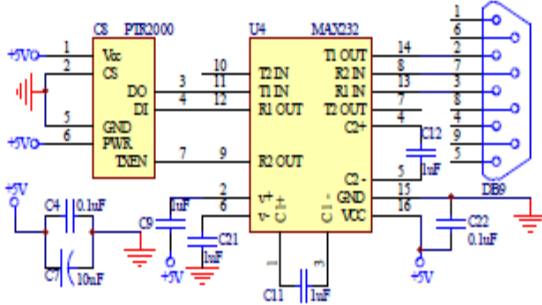

Fig.6 shows a PTR2000 module linked to a MAX232 MSP430F135 sending transaction data to a host computer and receiving commodities data from a weigh scale via an RS232 connection.

### 3. Software design MSP430 data acquisition program

Initiating the system, scanning the keyboard, driving the LED, receiving commodity data, reading and writing the current clock/data parameter in the PCF8563, storing transaction details in the AT45DB081 flash memory, and transmitting them to the host PC wirelessly are only some of the primary functions of the MSP430 application. MSP430's software process entails disentangle the meaning of the code in the instructions, alter the system flag, set up the internal register, call related I2C/SPI subroutine to read and write external device according to the semantic.

#### Calibration

The initial 05 kg weight was converted to 03.3 V voltages after several rounds of real measurement and serial adjustments. The conditioned voltage is then sampled using a 12-bit sigma-delta ADC module, yielding a resolution of 04096. A moving-average filter is applied to the final output to increase accuracy. If we assume that the AD result at time  $n$  is  $u(n)$ , then the output of the filter at time  $n$  is  $x(n)$ , where  $L$  is the length of the moving window average filter. (2).

$$x(n) = \frac{1}{L-2} \left[ \sum_{k=1}^L u(n+k) - \max_{k \leq L} u(n+k) - \min_{k \leq L} u(n+k) \right] \quad (2)$$

The maximum and lowest values of  $u(n)$  are denoted by  $\max u(n)$  and  $\min u(n)$ , respectively, in equation (2). When a new AD result is acquired, the first of the previous  $L$  number of AD results is removed, the rest advance one place, and the new

result is added, as stated in (2). Into the slack spot. After removing the sequence's extremes, the average mean of the left  $L-2$  number of AD findings may be determined. The mean  $x(n)$  is just the filter's output. The rate of AD and the amount of time required to do the weighing process determine  $L$ .  $L=8$  is utilized after several iterations of real measurement. Calibration is performed using a weight of 20 g. Table 1 displays the correlation between body mass and AD diagnosis. Scale transformation is shown in Fig. 7; adjustment is unnecessary as a result of strong linearity and measurement accuracy.  $X$  is the AD outcome, while  $y$  is the load.

| Weight(g) | AD result | Weight(g) | AD result | Weight(g) | AD result |
|-----------|-----------|-----------|-----------|-----------|-----------|
| 20        | 4         | 80        | 18        | 140       | 31        |
| 40        | 9         | 100       | 22        | 160       | 36        |
| 60        | 13        | 120       | 26        | 180       | 40        |
| 200       | 44        | 260       | 58        | 320       | 72        |
| 220       | 49        | 280       | 63        | 340       | 77        |
| 240       | 54        | 300       | 67        |           |           |

Table 1 Weight and AD result

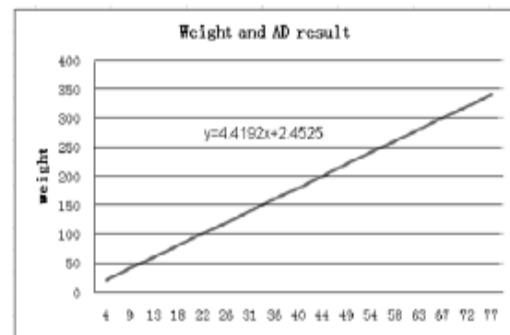

Fig.7 Scale transformation

#### Host PC side software

The software on the host PC's side primarily serves to receive transaction details, transfer commodity data, and serve as a user interface. The Visual Basic programming language was used to create the program. The serial data is read and manipulated using an MSComm control object. Wireless networks are managed using a serial port on a personal computer. Module for receiving and sending data using the tenable property of the MSComm control object. After level conversion, the RTS pin on the serial port is set to high, meaning that the PTR2000 is in transmission mode when  $RTSEnable=False$ . With

RTSEnable=Ture, the RTS pin of the serial port is low; hence, the PTR2000 is set up in a receiving state after level conversion.

#### 4. Conclusions

The electronic scale can both measure the weight of the commodity and send and receive data about the commodity through wireless communication and a serial connection on a host computer. A maximum of 5 kg may be placed on the scale, and the precision is 1g. To what end are INA326 and OPA2234 being used? Has completed the code to boost a feeble signal and limit user input. The MSP430 and PTR2000 combo is able to talk to the host PC without any problems. MAX232 accomplishes the voltage to level shift. The user-friendliness of the interface makes it simple to adjust commodity prices and do research on customer preferences. If the system can accommodate numerous slave electronic scales, that would be ideal.

#### References

- [1] Texas Instruments Incorporated. (2010): 'MSP430x13x, MSP430x14x, MSPx14x1 mixed signal Microcontroller', Datasheet SLAS272F.Rev. G, pp. 1-3.
- [2] Andreas Dannenberg. (2004): 'MSP430F42x single chip weigh scale, Application Report '. Datasheet SLAA220.pp. 2-5.
- [3] Burr-Brown from Texas Instruments Incorporated. (2005): Precision, rail-to-rail I/O instrumentation Amplifier'. Datasheet SBOS222D.pp. 1-3.