



IJITCE

ISSN 2347- 3657

International Journal of Information Technology & Computer Engineering

www.ijitce.com



Email : ijitce.editor@gmail.com or editor@ijitce.com

IOT-BASED ANDROID-CONTROLLED SURVEILLANCE ROBOT

¹THOTA SRAVANTI, ²NENAVATH DASHARATH, ³P.SHANKAR, BALKUMAR REDD

ABSTRACT

An enormous need exists for security services, notably in residential areas, places of employment, militaries, and on corporate boards of directors. The necessity for security measures to protect people, property, and the borders of nations has always been felt throughout history. Providing surveillance in particularly sensitive locations, terrorist hotspots and other high-risk areas without putting human lives in danger is the purpose of this initiative, which is still in its early stages. In this project, the Raspberry Pi is controlled by an Android Bluetooth application, and a 360-degree night vision camera is utilised for surveillance purposes to capture images. When you use the camera, you can watch a live stream of the film that it gathers, which can also be seen using an Android app, which is available for download. It also features a complete 360-degree rotation, which allows for more extensive monitoring, as well as the ability to store both video and audio from the camera's software. When the spy robot chassis, which is powered by a Raspberry Pi, is interfaced with an Android app, the direction controls are communicated to the chassis by a Bluetooth module, which is connected to the chassis over a Bluetooth connection.

KEY WORDS: *Arduino, Raspberrypi, Camera, Surveillancerobot, Bluetooth*

1. INTRODUCTION

Mechanical devices that can conduct physical tasks under the direction of a human or with the assistance of artificial intelligence are specified in the area of mechanics. Recent years have seen significant advancements in the production of processors and sensors, which has resulted in the creation of more intelligent robots.

It is undeniably true that one of the most essential uses for robots is the monitoring of people and objects. Every person, place, and object is always under surveillance, which is the process of tracking them down during the course of the day. This is often utilised in military applications where it is critical to keep track of the position of the adversary as well as

the boundaries between the two sides of the battlefield. The overall security and stability of a country cannot be achieved without their participation. Human surveillance is a tactic that entails placing persons in or near sensitive areas in order to observe what is taking place. However, this kind of monitoring has its limitations since humans are unable to perform in unsafe or inaccessible environments, rendering the monitoring worthless.

These settings either put a person's life in danger or render him subject to capture by the adversary's soldiers,

¹M.Tech Associate Professor, ndasharath86@gmail.com
²M.Tech Assistant Professor, shankardvk48@gmail.com
³POLUY, M.Tech Assistant Professor, balureddy5586@gmail.com
Department :ECE
Nagole Univerisity Engineering and Technology Hyderabad

depending on how they are constructed. Because of the considerable advancements in network and robot technology, it is now possible to monitor vital places from a distance, using the Internet as a communication medium. Rather of deploying individuals, robots are being used to take the role of humans. In both aerial and terrestrial environments, according to the researchers, the robots can gather information that is not visible to people, allowing them to acquire information that is not visible to humans. Incorporating price sensors and cameras into the robot's design makes it possible to gather data for simply entering the static IP address machine in a web browser. When motion is recognised in a video, the video is either saved in a drop box or in a separate Windows shared folder, depending on the conditions of the detection. Manual control methods in a robot that operates in a wireless mode and monitors people or places is a difficult task, but it can be accomplished in the most cost-effective and user-friendly way possible with the right tools and techniques.

2. Existing system

There are a range of apps that may be used by the wifi-enabled robots when there are visitors in the home. Any visitors that come inside the building will be seen and monitored by the robot. In looks, he resembles a spy. It is only for surveillance reasons that the robot is now in use, and a closed-circuit television camera is also in use for this purpose. There isn't much of a difference between the two of them. This is a big weakness in the existing system since it does not concentrate appropriately in many areas, which is a huge flaw in any system.

3. PROPOSED SYSTEM:

Recent years have seen the development of a variety of systems that allow for the remote control of a wide range of home and office applications, demonstrating that technical advancements are undoubtedly possible and that these innovations have had an influence on our lives and the way we live. It is becoming more common to administer a variety of home and business applications from a distance, and in recent

a particular purpose from a distance, allowing the robot to collect data from a variety of locations. In recent years, advances in wireless communication technology have made it feasible to establish a smooth connection with robots and broadcast real-time video without the need of wires. The installation and configuration of a high-definition security camera powered by a Raspberry Pi in the region where we wish to keep an eye on things has been completed. You may see live steam videofrom anywhere in the world by

that has been provided to the years, we have witnessed an explosion of technologies that enable this kind of management.

Mobile robots, as opposed to fixed robots that are bound to a certain region or environment, are robots that have the capacity to move about and interact with their surroundings. There are a lot of laboratories and research groups from different universities and organisations that are completely dedicated to the study of mobile robots because of their tremendous potential and widespread applications in areas like as industry, military security, entertainment, and others.

In order to offer live video feed, a network camera that has been put on the robot is used.

We have created a custom programme that will allow us to operate the robot from a distance using a smartphone.

Livig video streaming is included in our app, and you may view it whenever it is convenient.

Actual-world applications for this technology include a diverse variety of various applications for this technology.

In this project, we make use of an Arduino board, which is far less expensive than a Raspberry Pi computer.

Rather of spending money on a high-end camera, we utilise an Android phone for this purpose.

SCHEMATIC DIAGRAM

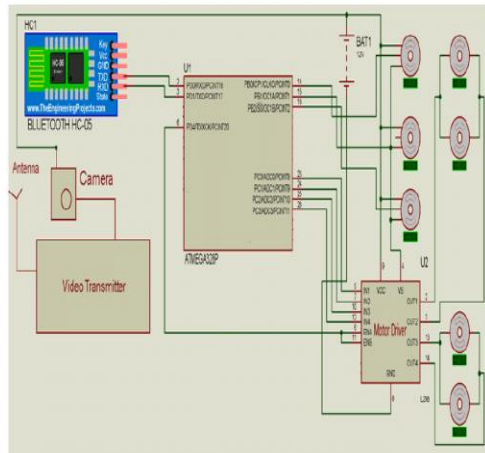

Figure 3.1 Schematic Diagram of Android controlled surveillance robot.

The Raspberry Pi acts as the core processing unit for the circuit. Single board computer the size of a credit card that is powered by a 900MHz quad-core ARM Cortex-A7 CpU processor with 1GB of RAM and is the size of a credit card. The vehicle is also equipped with two infrared obstacle sensors, which allow it to identify barriers that you would otherwise be unable to perceive due to the fact that you are not physically there. In the case that it identifies an object, it will adjust its route in order to avoid colliding with the object at issue. A huge number of sensors have been installed on the robot, as previously stated in this article. An additional function is a camera that may be used for video surveillance of human beings, which is another aspect of the device. A motion sensor has also been installed to detect the movement of persons on the roadway. If a person is recognised, the system will activate a camera module, which will take a picture of them. GPIO on the Raspberry Pi is also equipped with an L293 motor driver, which enables for the proper current to be sent to the motors. We have reached a mutually beneficial deal.

WORKING:

It is demonstrated that the raspberry pi is connected to the first power source that is depicted in this block diagram. In addition, energy is being given to the Bluetooth port, and a flashing light will be seen on the device.

Download and install the Bluetooth termina HC-05 application on your smartphone, then choose the HC-05 Bluetooth device.

Following the establishment of a connection between the gadget and the Bluetooth device

When the Bluetooth terminal HC-05 is successfully connected, it will go to the command area and request that the asque command be used to start the robot.

The desire is communicated via the use of capital letters.

In the event of a FORWARD command being sent, the order will be carried out in the FORWARD direction.

Following that, it will give the BACKWARD command and travel in the other direction. •

In the next step, it will give the LEFT command, which will cause the left wheel to come to a complete stop and the right wheel to begin moving in the desired direction.

The command will be re-run once it has been completed. RIGHT, then come to a complete stop on the right wheel and go to the left wheel in the opposite direction as the right wheel.

Download and run the IP webcam programme.

A hotspot is available in the IP web cam programme.

Following that, another mobile phone is grabbed and linked to the wi-fi network

To find the IP code, open Google Chrome and type it in.

Using real-time streaming video, you may connect your IP web cam to your phone's wi-fi terminal and see it in real time.

The functioning model of the proposed surveillance robot, which was conceived and manufactured with the help of the Raspberry Pi module, was finished successfully. When the circuit was tested under a range of various conditions, its performance was evaluated. Specifically, a 360-degree night vision camera was utilised in combination with an Android bluettoth app to control and monitor the circuit in order to provide surveillance for it. The circuit was put through its paces to determine its accuracy in measuring a range of distances under a variety of air conditions. With its short response time, it is quite effective. The surveillance robot module is in perfect working order. It alters its behaviour in reaction to the presence of the night vision camera on board. Because of the Internet of Things, we were able to keep prices as low as possible while simultaneously enhancing efficiency. The inclusion of this

implementation has been a key component in the circuits of important fast-consuming technologies for a long time.

4. PROBLEM STATEMENT

Industrial carrying robots, locomotive robots, self-guided vehicles (such as petrol robots, pathfinder robots, industrial carrying robots), and other robotic technologies, among others, are improving the quality of human life for which they were originally developed today. However, due of the intricacy of their design, the current analytical robots that are available are equipped with a lot of hardware and controllers, which makes them expensive and essential to debug because of their complexity. Consequently, in order to relieve humans of this burden, new ways as well as enhanced advances via the employment of lightweight robots will need to be devised and implemented.

5. RESULT

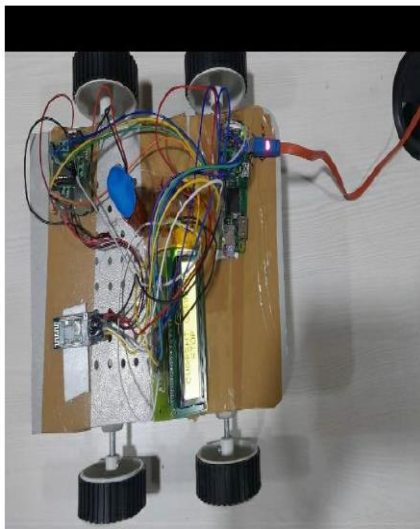

Fig 5.1 Final report on surveillance robot by using raspberry pi

6. CONCLUSION

The usage of International Journal of Engineering Science and Computing, April 2019 21258, allows for the connecting of sensors with Raspberry Pi, the interfacing of actuators (motors) with Raspberry Pi, and the communication with the system. On a web page, HTTP, data, and live streaming are all shown. In this research, we looked at several types of direct sensors, the Raspberry Pi Board, and motor controllers among other things. This technology is useful in a restricted number of situations, such as home security and for military personnel. It puts a stop to the employment of various sensors to provide early disaster warning to soldiers. Human life is preserved in high-risk locations as a result of its use. A huge number of sensors are included into the Raspberry Pi board, and these sensors provide messages to a Web page through Wi-Fi connection.

7. FUTURE SCOPE

There are several changes that can be made to the current design and technology, as well as numerous new features that can be included to make the system even more helpful.

In its current state, autonomous navigation is carried out in a blind way, meaning that the robot does not keep track of the direction in which it is travelling. Consequently, we would want to equip the robot with an electronic compass in the future to assist it in keeping track of its whereabouts. With the aid of encoders, it is possible to achieve a more effective kind of cell-based navigation, for which a provision has been provided in the software. It is possible to include a more powerful embedded computer capable of handling HTTP requests into the robot itself, enabling it to be further customised. We put our robot and arm through the following tests once we had successfully produced them and programmed them in line with our specifications:

1. The introduction of conveyor belts, which were utilised to transfer the vehicle, made it simpler for the vehicle to go across unlevel ground.
2. A graphical user interface (GUI) for connecting with cameras and displaying video output.
- 3) The employment of the arm in any and all of its possible configurations.

4. The robot executes an action in line with the instructions given by the user.

The military ministry would need a number of adjustments if this prototype were to be put into use.

These would include the following alterations:

- The capacity to move about freely on the ground
- Design using computer-aided technology (CAD)

It will be possible to see in all directions thanks to the installation of extra cameras.

REFERENCES

1. [1]. Vanitha, M., M. Selvalakshmi, & R. Selvarasu. "Monitoring and controlling of mobile robot via internet through Raspberry Pi board." *Science Technology Engineering Management (ICONSTEM), Second International Conference on IEEE, 2016.*
- [2]. MohdNorAzni, M.N.H, Vellasami, L; Zianal, A.H; Mohammed Home Automation System with Android Application, *IEEE 2016.* [3]. Pavithra.D, RanjithBalakrishnan, Iot based monitoring and control system for home automation *IEEE 2015.*
- [4]. KetanDumbre, SnehalGaneshkar, AjinkyaDhekne, *Robotic Vehicle Control using Internet via Webpage and Keyboard International Journal of Computer Applications(0975-8887 2.), Volume 114-No.17, March 2015.* [5]. Gaurav S Bagul, Vikram C Udawant, Kalpana V Kapade and Jayesh M Zope, *IOT Based Surveillance Robot International Journal of Trend in Research and Development, Volume 5(2), (ISSN: 2394-9333) March 2017*
3. ChristianHernandez, Racielpoot, LizzieNarvaez, ErikaLlanes and Victor Chi, "Design and implementation of a System for Wireless Control of a Robot", *IJCSI International Journal of Computer Science Issues, Vol.7, Issue 5, September 2010*
4. MejdSafran and Steven Haar, "Arduino and Android Powered Object Tracking Robot" [online] available: http://faculty.ksu.edu.sa/mejdi/Publications/Android_Arduino_Robot.pdf
5. TheJavaTutorials: AllAboutSockets [online]. Available <https://docs.oracle.com/javase/tutorial/networking/sockets>, March 2013
6. IP Webcam, Google Play [online] Available: <https://play.google.com/store/apps/details?id=com.pasWebcam&hl=en>, February 2012.
7. Android Developers Site API Guides [online]. Available : <http://developer.android.com/guide/components/index.html>, October 2012
8. .com/guide/components/index.html, October 2012
9. The Arduino Uno Website [online]. Available 41
10. : <https://Arduino.cc/en/Main/arduinoBoardUno>, September 2012
11. Arduino Language Reference [online]
12. Available: <https://Arduino.cc/en/Reference/HomePage>, September 2012
13. Shiffman, Daniel (September 23, 2009). "Interview with Casey Reas and Ben Fry". *Rhizome.org*
14. *Android USB Host+ Arduino: How to communicate without rooting your Android Tablet or phone [online]. Available: https://android.serverbox.ch/?p=549, September 2012. JigneshPatolia, Haard Mehta, Hitesh Patel, Patel.V.T.*
15. "Arduino Controlled War Field Spy Robot Using Nightvision
16. Camera And Android Application". Department of
17. Electronics And Communication of Engineering, Charotar
18. University of Science And Technology, Changa, Anand,
19. Gujarat -388421, India.(2015)
20. [2] Mohammad Shoeb Shah, Borole. P.B. "Surveillance
21. And Rescue Robot Using Android Smart Phone And
22. Internet". *International Conference on Communication And*
23. *Signal Processing, India. (2016)*
24. [3] Manish Yadhav, Vibha Singh, VinayUniyal, Manish Singh.
25. "Smart Aero Amphibian Surveillance System" Department of
26. *Electronics Engineering, Thakur College Of Engineering And*
27. *Technology, Mumbai, India.(2016)*